



ZIEGLER - Portable Fire Pump

ULTRA POWER 4



Portable pump with Volkswagen 3 cylinder 4 stroke aluminum engine with electronic fuel injection designed as PFPN 10-1000 and 10-1500 tested according to EN 14466.

Simplest operation due to automatic engagement of the pump. The ULTRA POWER 4 is the most powerful portable pump according to EN 14466. The pump operator will be relieved thanks to an automatic control of the outlet pressure of the Tourmat D. The pumping operation is possible without additional switching.



BAVARIA EGYPT (S.A.E.)
Gisir El Suez St. Block 109, Industrial Zone,
Ismailia Desert Road, Cairo-Egypt
P O Box: 2016/11111 Cairo-Egypt

Tel. : + 20 (2) 2182 0604 / 5 / 6
Fax : + 20 (2) 2182 0609
Website : www.bavaria-firefighting.com
Email : international.sales@bavaria.com.eg



BAVARIA Brandschutz Industrie GmbH & Co. KG
Regensburger StraBe16,
D-93449 Waldmunchen
Germany

Tel. : + 49 (0) 997 29 401-0
Fax : + 49 (0) 997 29 401-17
Website : www.bavaria-firefighting.de
Email : info@bavaria-firefighting.de



ZIEGLER - Portable Fire Pump, Type: **ULTRA POWER 4**

Top fire fighters choose top performance: the **ULTRA POWER 4**.

Features:

- Simplest operation
- Automatic centrifugal clutch operation
- Illuminated display (day and night)
- Pump pressure governor Tourmat D
- Compact external dimensions
- Worldwide service network
- Comprehensive accessories



Simplest operation due to automatic engagement of the pump. The ULTRA POWER 4 is the most powerful portable pump according to EN 14466. The pump operator will be relieved thanks to an automatic control of the outlet pressure of the Tourmat D. The pumping operation is possible without additional switching.

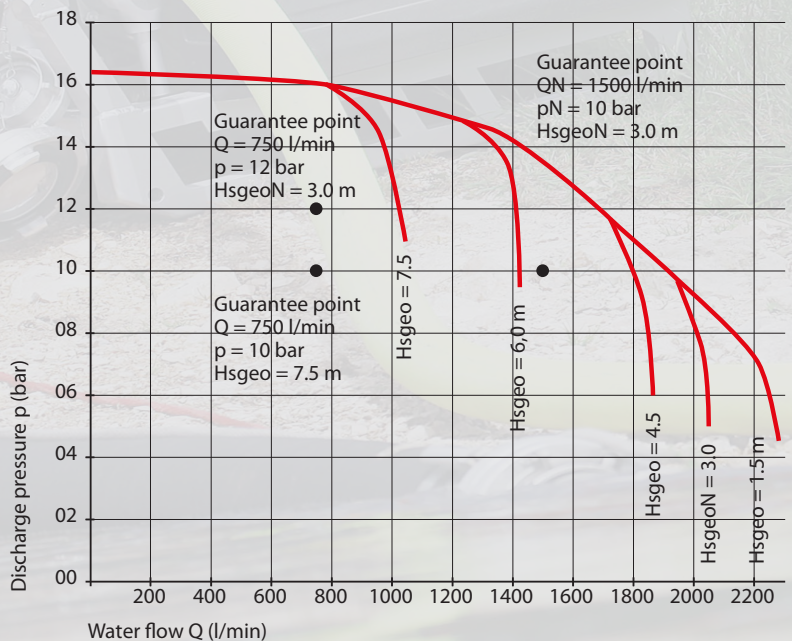

ZIEGLER - Portable Fire Pump, Type: **ULTRA POWER 4**

Features:

- Engaging by automatic centrifugal clutch.
- Automatic rpm limitation at suction action.
- State-of-the-art engine technology, environment-friendly,
- low vibration,
- smooth running.
- Extensive Volkswagen service network for maintenance.
- Optimum operation of the portable pumps thanks to new control panel.
- All controls are clearly and user-friendly arranged on a panel.



Non-stop operation by external refuelling



Multi-function display
- ease of use,

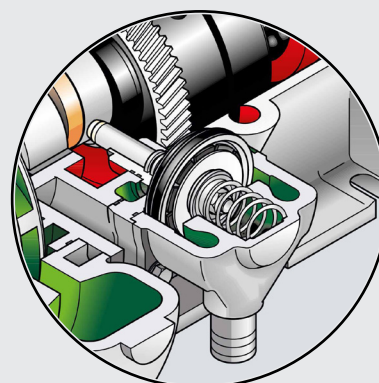

TROKOMAT PLUS
The patented Ziegler priming system

TOP PERFORMANCE OVERVIEW:

PUMP PFPN 10-1000/10-1500 ACCORDING TO DIN 1028

Pump PFPN 10-1000/10-1500 according to DIN 1028 One-stage centrifugal fire pump of high efficiency. Water-bearing parts of sea-water resistant light alloy and corrosion-resistant steel. Sealing of the pump by radial seals. With suction inlet size A and two delivery outlets size B with self-closing screw-down valves, all of them with tight couplings and blank caps. Power transmission from engine via automatic centrifugal clutch.

GAUGES AND CONTROLS:

- Improved handling thanks to clear multifunction display:
- Graphic tank indication with reserve warning light
 - Rpm counter and control light for suction rpm limitation
 - Working hour recorder
 - Warning and control lights for cooling water, oil pressure and charging control

PRIMING SYSTEM:

FULLY AUTOMATIC TROKOMAT PLUS

ENGINE:

Volkswagen 3 cylinder 4 stroke aluminium engine with electronic fuel injection. Output 50 kW at 5400 rpm. State-of-the-art engine technology, environment-friendly, low vibration, smooth running. Extensive Volkswagen service network for maintenance. Automatic centrifugal clutch. Optimum operation thanks to new Z-Control panel with clear multi-function display.

STARTING SYSTEM:

Electric starter, recoil starter as option



ZIEGLER - Portable Fire Pump, Type: **ULTRA POWER 4**



**Powerful use,
Reliable handling.**

REFUELLING

Shapely symmetric plastic cowling. 17 l Fuel tank for non-leaded premium gasoline (ROZ 95) or regular gasoline (ROZ 91).

LIGHTING

1 Halogen spotlight extendible. Swivelling and tiltable in all directions.

CARRYING FRAME OF THE PORTABLE PUMP

High-strength light metal frame with four ergonomically hinged and turnable handles as well as rubberized cold hand guard.

EASY TO HANDLE

After opening of the cover checking respectively refuelling of cooling agent and engine oil is particularly easily possible.

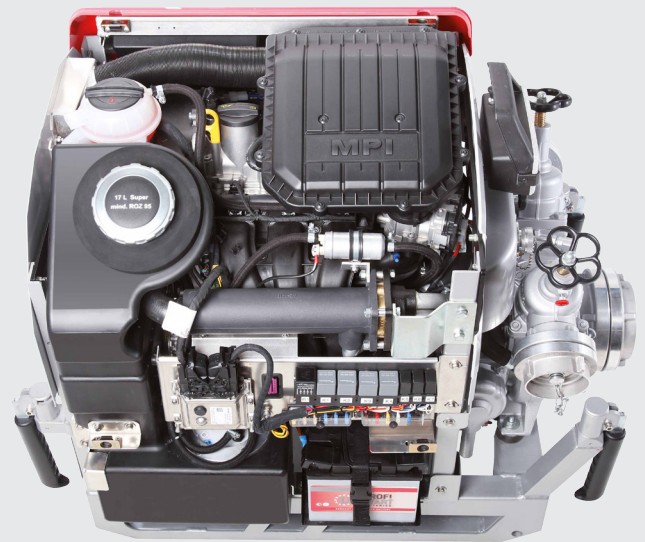

Illustrations might show accessories and/or special equipment which are not included in the standard scope of supply or performance range.



ZIEGLER - Portable Fire Pump, Type: **ULTRA POWER 4**

Technical Data	
NOMINAL OUTPUT	1000 l/min at 10 bar and 3 m geod. suction height 1500 l/min at 10 bar and 3 m geod. suction height
PUMP OUTPUT	<ul style="list-style-type: none"> • at 3 m geod. suction height approx. 1900 l/min at 10 bar • at 3 m geod. suction height 2000 l/min at 8 bar • at 1,5 m geod. suction height 2150 l/min at 4 bar • at 7,5 m geod. suction height 1050 l/min at 8 bar
SUCTION TIME	<ul style="list-style-type: none"> • 5 s at 3 m geod. suction height • 19 s at 7,5 m geod. suction height
PUMP	<ul style="list-style-type: none"> • FPN 101500- according to EN 1028 • One-stage centrifugal fire pump of high efficiency. • Water-bearing parts of sea-water resistant light alloy or stainless steel. • Sealing of the pump by radial seals. • With suction inlet size A and two delivery outlets size B with self-sealing screw-down valves, all of them with tight couplings and blank caps. • Power transmission from engine via automatic centrifugal clutch.
PRIMING SYSTEM	Proven fully automatic TROKOMAT PLUS
GAUGES AND CONTROLS	<ul style="list-style-type: none"> • All control elements are functionally integrated in the cowling. • Pressure gauge and mano-vacuummeter • Start button • Turning handle for throttle (controls electronically) • Control panel with bright LED lighting • Multi-function display for: graphic tank indication with reserve warning light, rpm counter, control light for suction rpm limitation, working hour recorder, warning and control lights for cooling water, oil pressure, charging control
ENGINE	<ul style="list-style-type: none"> • Volkswagen 3 cylinder 4 stroke aluminium engine with electronic fuel injection • Output 50 kW at 5400 rpm. • Displacement 999cm³ • Cooling by closed cooling water circulation with heat exchanger and additional cooler. • Electronic two-stage rpm limitation for suction and max. rpm acting on the injection unit, contactless battery ignition, maintenance-free valve operation thanks to roller lever. • Starter: electric start with one-man emergency system through starter cable (optionally) • Shapely symmetric plastic cowling • 17 l Fuel tank for unleaded premium gasoline (ROZ 95), alternatively regular gasoline (ROZ 91), Engine control by knock sensor • Fuel pump with filling level indicator integrated in tank, fuel cock is deleted
LIGHTING	1 Halogen spotlight, extendible and can be swivelled and tilted in all directions
CARRYING FRAME	High-strength light metal frame with four ergonomically hinged and turnable handles as well as rubberized cold hand guard.
DIMENSIONS	<ul style="list-style-type: none"> • Length 1039 mm • Width 720 mm • Height 846 mm
WEIGHT	approx. 188 kg (ready for action)